

POSISTOR® and "POSISTOR" in this catalog are the trademarks of Murata Manufacturing Co., Ltd.

# POSISTOR® for Heater



## POSISTOR® for Constant Temperature Heating

These "POSISTOR" are designed for various applications for constant temperature heating purpose. Wide range of temperature characteristic shall make easier to select most suited heater device matching to the application.

### ■ Features

1. The heater element itself regulate designated temperature range.  
(Temperature can change depending on how to use it)
2. The temperature pulsation which is observed in case on-off temperature control system can be eliminated.
3. Output wattage is decreased automatically when heat radiation is decreased.  
(Overheating is very small compared to constant wattage heaters)
4. Compact and flat surface makes it easy to install in applications.  
(PTWTA series has electrically insulated heating surface)
5. Depending on application, these PTCs realize dual voltage use.  
(Output wattage does not change much between 100V through 260V)

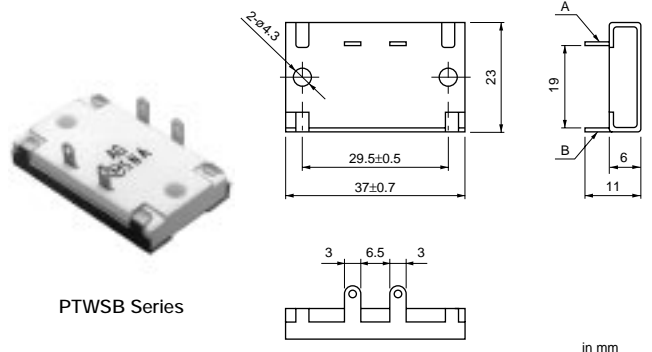

PTWSB Series

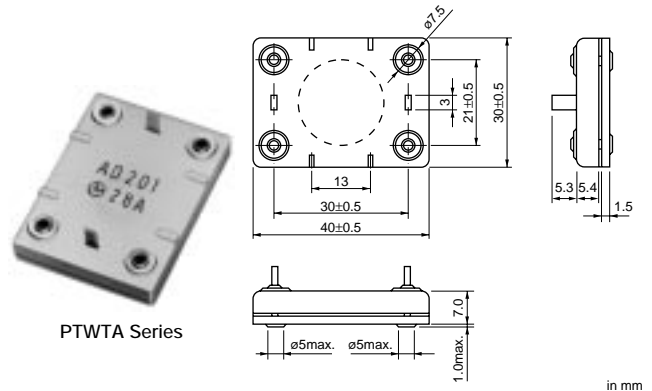

PTWTA Series

### ■ Applications

- Heated vessels (electronic jars, tea pots, etc.)
- Contact lens cleaner
- Massager
- Electric pot
- Portable travel iron
- Fragrance

Part Number	Curie Point (°C)	Rated Volt.	Max. Volt. (Vrms)	Inrush Current (A)	Steady State Current (at 120Vrms) (mA)	Steady State Current (at 220Vrms) (mA)	Surface Temp. (Nominal Value) (°C)
PTWSB1BC201T260A00	92 ±7°C	120/220Vrms.	260	5.0	28 ±20%	17 ±20%	105
PTWSB1AS201T260A00	135 ±7°C	120/220Vrms.	260	5.0	33 ±20%	21 ±20%	130
PTWSB2AH201T260A00	207 ±7°C	120/220Vrms.	260	5.0	58 ±20%	35 ±20%	185
PTWSB2AG201T260A00	225 ±7°C	120/220Vrms.	260	5.0	65 ±20%	39 ±20%	200
PTWTA1AD201T260A00	280 ±7°C	120/220Vrms.	260	10.0	-	75 ±30%	285

Inrush current based on 220Vrms.

Operating temperature range PTWSB1/PTWTA: 0 to +60°C, PTWSB2: 0 to +85°C

## Terminal Connection

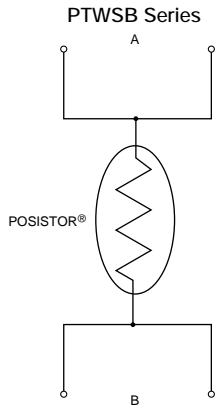

## Power Consumption vs Radiative Plate

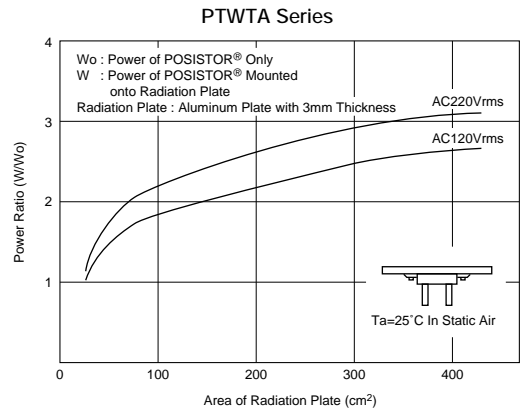
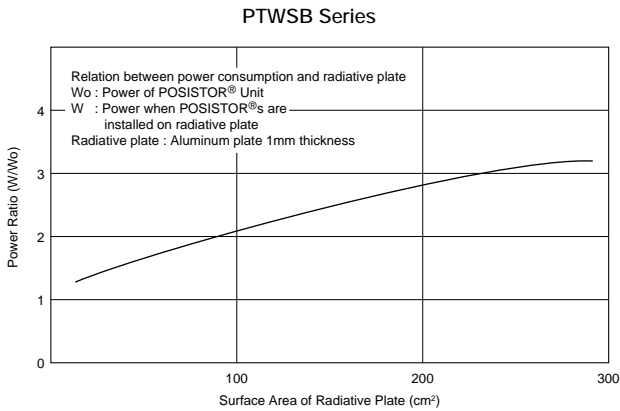

## Output Power vs Ambient Temperature

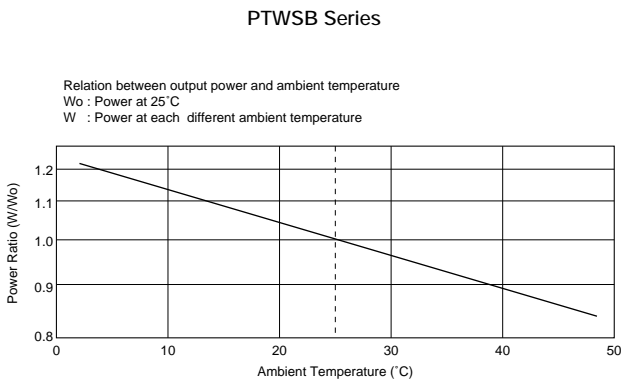

## Radiation Plate vs Steady State Temperature

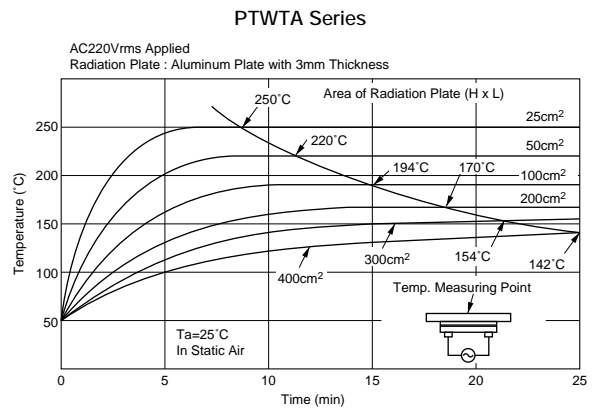

## Area of Radiation Plate and Temp. Deviation

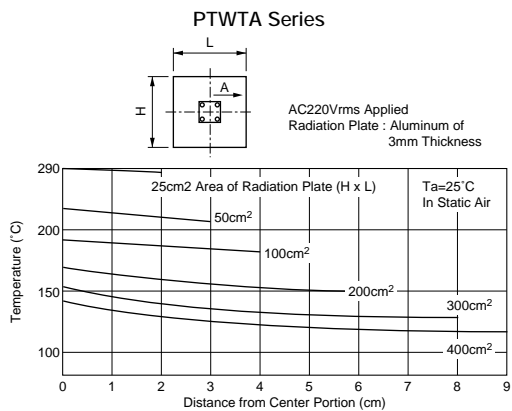

### ■ Continuous Load at High Temp.

PTWSB Series

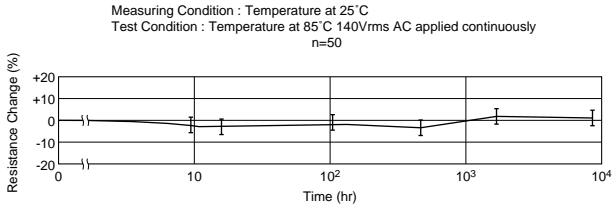

### ■ Intermittent Load at High Humidity

PTWSB Series

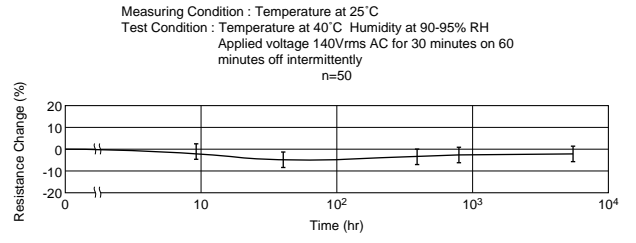

## Standard Type POSISTOR® ⚠Caution/Notice

### ■ ⚠Caution (Soldering and Mounting)

1. Please do not fail to install the current fuse in series so that applied equipment is protected when "POSISTOR" is adversely affected by misuse or some other reason.
2. Please confirm safety of your products after installing "POSISTOR" by conducting suitable endurance test for the application.
3. Please provide proper insulation for PTWSB series because metallic plate is electrically hot too.

### ■ ⚠Caution (Storage and Operating Conditions)

This product is designed for application in an ordinary environment (normal room temperature, humidity and atmospheric pressure). Do not use under the following conditions because all these factors can deteriorate the characteristics or cause product failure and burn-out.

1. Corrosive gas or deoxidizing gas (Chlorine gas, Hydrogen sulfide gas, Ammonia gas, Sulfuric acid gas, Nitric oxide gas, etc.)
2. Volatile or flammable gas
3. Dusty conditions
4. Under vacuum, or under high or low-pressure
5. Wet or humid conditions
6. Places with salt water, oils, chemical liquids or organic solvents
7. Strong vibrations
8. Other places where similar hazardous conditions exist

### ■ ⚠Caution (Others)

Be sure to provide an appropriate fail-safe function on your product to prevent secondary damage that may be caused by the abnormal function or the failure of our product.

### ■ Notice (Storage and Operating Conditions)

#### PTWSB Series

Store the product under the following condition to prevent from change of characteristic or discoloration of terminal.

1. Storage condition  
Temperature: between -10 and +40(degree C)  
Humidity: less than 75% RH (not dewing condition)
2. Term  
Please use this product within 6 months after shipment by first-in first-out stocking system.

3. Handling after unpacking  
After unpacking of the minimum package, reseal it promptly or store it inside a sealed container with a drying agent.
4. Place  
Do not store this product in corrosive gas (SOx, Cl etc.) or under sun-light.

### ■ Notice (Storage and Operating Conditions)

#### PTWTA Series

Store the product under the following condition to prevent from change of characteristic or discoloration of terminal.

1. Storage condition  
Temperature: between 0 and +40(degree C)  
Humidity: less than 85% RH (not dewing condition)
2. Term  
Please use this product within 6 months after shipment by first-in first-out stocking system.

3. Handling after unpacking  
After unpacking of the minimum package, reseal it promptly or store it inside a sealed container with a drying agent.
4. Place  
Do not store this product in corrosive gas (SOx, Cl etc.) or under sunlight.

## Standard Type POSISTOR® Notice

### ■ Notice (Soldering and Mounting)

#### PTWSB Series

1. Design assembling position of "POSISTOR" considering heatproofing.
2. Make the heat resistance as small as possible, between the "POSISTOR" and the place it is connected. Do not use an insulating sheet which is poor in heat transmission. Install the "POSISTOR" in the flat surface to maximize the function. Application of heat resisting grease (e.g. silicone grease), into interfaces of "POSISTOR" substrate - insulator - material to be heated, will permit effective heat transmission.
3. When more than one "POSISTOR" is used, be sure to connect them in parallel. If "POSISTOR"s are connected in series, they don't operate normally.
4. When lead wires are connected to "POSISTOR", use rosin type flux which includes less than 0.2wt% of chlorine. Also pay attention to connecting method in order to prevent "POSISTOR" from invasion of flux, and to heatproof connecting materials (ex: solder, etc).
5. This product generates heat at operation, and direct touch to the surface can hurt human finger or skin. Pay attention at the installation to prevent direct touch from outside.

### ■ Notice (Soldering and Mounting)

#### PTWTA Series

1. Heat resistance of the mounting part must be considered in designing.
2. Four mounting holes 1.0 to 1.5 mm in depth and 5 to 5.5 mm in diameter are required on the heated part contacting "POSISTOR".
3. Apply power with "POSISTOR" mounted into the part heated. If power is applied to "POSISTOR" alone, the alumina case may be broken.
4. When more than one "POSISTOR" is used, be sure to connect them in parallel. If "POSISTOR"s are connected in series, they don't operate normally.
5. When lead wires are connected to "POSISTOR", spot welding method should be adopted. Recommended material of lead wires is Nickel.
6. This product generates heat at operation, and direct touch to the surface can hurt human finger or skin. Pay attention at the installation to prevent direct touch from outside.

### ■ Notice (Rating)

Do not apply voltage the maximum voltage.

Because their characteristics might be worse and PTC element may be destroyed.

● Part Numbering

PTC Thermistors (POSISTOR®) for Heater

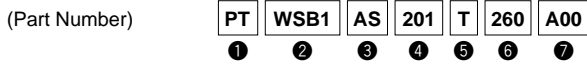

① Product ID

Product ID	
<b>PT</b>	PTC Thermistors

② Series

Code	Series
<b>WSB1</b>	Heater Standard Type B1 Series
<b>WSB2</b>	Heater Standard Type B2 Series
<b>WTA1</b>	High-temperature Heater A1 Series

③ Temperature Characteristics

Code	Temperature Characteristics
<b>AD</b>	Curie Point 280°C
<b>AG</b>	Curie Point 220°C
<b>AH</b>	Curie Point 200°C
<b>AS</b>	Curie Point 130°C
<b>BC</b>	Curie Point 90°C

④ Resistance

Expressed by three figures. The unit is ohm (Ω). The first and second figures are significant digits, and the third figure expresses the number of zeros which follow the two figures.

Ex.)

Code	Resistance
<b>201</b>	200Ω

⑤ Resistance Tolerance

Code	Resistance Tolerance
<b>T</b>	+500/-0%

⑥ Maximum Voltage

Code	Maximum Voltage
<b>260</b>	260V

⑦ Individual Specifications

Code	Individual Specifications
<b>A00</b>	Structure, others

#### **for EU RoHS Compliant**

- All the products on this catalog are complied with EU RoHS.
- EU RoHS is "the European Directive 2002/95/EC on the Restriction of the Use of Certain Hazardous Substances in Electrical and Electronic Equipment".
- For more details, please refer to our website 'Murata's Approach for EU RoHS' (<http://www.murata.com/info/rohs.html>).

**△Note:**

**1. Export Control**

〈For customers outside Japan〉

No muRata products should be used or sold, through any channels, for use in the design, development, production, utilization, maintenance or operation of, or otherwise contribution to (1) any weapons (Weapons of Mass Destruction [nuclear, chemical or biological weapons or missiles] or conventional weapons) or (2) goods or systems specially designed or intended for military end-use or utilization by military end-users.

〈For customers in Japan〉

For products which are controlled items subject to the "Foreign Exchange and Foreign Trade Law" of Japan, the export license specified by the law is required for export.

**2. Please contact our sales representatives or product engineers before using the products in this catalog for the applications listed below, which require especially high reliability for the prevention of defects which might directly damage a third party's life, body or property, or when one of our products is intended for use in applications other than those specified in this catalog.**

- |                             |  |
|-----------------------------|--|
| ① Aircraft equipment        | ② Aerospace equipment  |
| ③ Undersea equipment        | ④ Power plant equipment  |
| ⑤ Medical equipment         | ⑥ Transportation equipment (vehicles, trains, ships, etc.)   |
| ⑦ Traffic signal equipment  | ⑧ Disaster prevention / crime prevention equipment   |
| ⑨ Data-processing equipment | ⑩ Application of similar complexity and/or reliability requirements to the applications listed above |

**3. Product specifications in this catalog are as of September 2007. They are subject to change or our products in it may be discontinued without advance notice.**

Please check with our sales representatives or product engineers before ordering. If there are any questions, please contact our sales representatives or product engineers.

**4. Please read rating and △CAUTION (for storage, operating, rating, soldering, mounting and handling) in this catalog to prevent smoking and/or burning, etc.**

**5. This catalog has only typical specifications because there is no space for detailed specifications. Therefore, please approve our product specifications or transact the approval sheet for product specifications before ordering.**

**6. Please note that unless otherwise specified, we shall assume no responsibility whatsoever for any conflict or dispute that may occur in connection with the effect of our and/or a third party's intellectual property rights and other related rights in consideration of your use of our products and/or information described or contained in our catalogs. In this connection, no representation shall be made to the effect that any third parties are authorized to use the rights mentioned above under licenses without our consent.**

**7. No ozone depleting substances (ODS) under the Montreal Protocol are used in our manufacturing process.**